

McMATH



CONTROLS & AUTOMATION INC

EDMONTON

CALGARY

#100 - 7503 Girard Road, Edmonton, AB T6B 2H2

Tel. 780.463.6366 Fax. 1.888.528.2785 Toll Free. 1.800.817.6493

info@mcmathcontrols.com

www.mcmathcontrols.com

MALLARD CONTROL

A BRAND OF  Taylor Valve Technology®

5646C

TRUSTED
SINCE 1958
WORLDWIDE

Precise.

Quality.

Reliable.



SINCE 1958



Mallard Control Model 5646C Pressure Regulator

Features

- > Rugged construction: Available in a carbon steel and aluminum diaphragm case.
- > Easy maintenance: Union connection between the diaphragm case and body allows easy access to trim parts without removing the regulator from the line.
- > Installation flexibility: The diaphragm case can be rotated in relation to the regulator body to allow installation in locations with limited space. The regulator may be installed in any position without affecting performance, provided the spring case vent is protected from the elements.
- > Wide range of flow capacities: A variety of orifice sizes are available to satisfy a wide range of flow requirements.
- > Tight shutoff: A soft seat disc, available in nitrile (Buna), or nylon, provides excellent shutoff performance.

The model 5646C pressure regulator provides economic control of natural gas, air, or a variety of other gases in commercial and industrial applications. This self-operated pressure reducing regulator is equipped with an integral pitot (boost) tube for increased flow capacities and stability. It is designed for inlet pressures up to 1000 psig and outlet pressures from 5 to 200 psig.



Flow Capacities, scfh of 0.6 Specific Gravity Gas, Based on 20% Droop

Specifications

- Body size: 1"
- Orifice sizes: 1/4", 3/8" & 1/2"(Standard) 1/8", 3/16"(Consult Factory)
- Maximum body inlet pressure: 1000 psig at 100 °F
- Maximum soft seat disc inlet / differential pressure
 - Nylon: 1000 psig / 1000 psid
 - Buna: 600 psig / 400 psid
- Operating temperature range: -20 to 250°F (-29° to 65°C)
- Approximate Weight: 6 lb., 8 oz. (3 kg)

Materials of Construction

Description	Material
Body	WCB
Spring & Diaphragm Casings	Die-Cast Aluminum
Diaphragm	Nylon-Reinforced Buna
O-Rings	Buna
Orifice	Stainless Steel
Disc Holder w/Soft Seat Disc	Stainless Steel w/Buna Disc Stainless Steel w/Nylon Disc

Inlet Pressure (psig)	Outlet Pressure (psig)	Port Diameter (in.)				
		All Body Sizes 1/8	3/16	1/4	3/8	1/2
10	5	325	730	1160	1980	2520
15		450	910	1540	2560	5000
20		540	1230	2100	3450	6900
30	5 to 20 psig	690	1610	2900	4850	11,250
50		1000	2550	4500	8000	13,500
75	Yellow Spring	1400	3130	5750	9770	14,600
100		1800	4270	7300	12,750	16,200
125	10 to 95 psig Dark Green Spring	2150	4550	8100	15,150	—
15		180	270	360	520	700
20		240	350	460	690	920
25		280	410	550	820	1090
50		460	680	910	1350	1800
75		630	950	1270	1870	2500
100		810	1210	1620	2390	3200
150		1160	1740	2330	3430	—
200		1520	2270	3040	4480	—
300		2230	3330	4450	6570	—
500	3640	5450	7290	—	—	
20	15 to 200 psig Yellow Spring	450	950	1480	2950	5100
30		660	1440	2530	4800	7480
50		1000	2480	4200	7700	11,500
75		1400	3000	5400	10,700	16,300
100		1800	3800	7850	14,200	18,500
150		2600	5800	11,500	18,000	—
200		3300	7350	14,300	22,200	—
400		6100	14,800	24,500	—	—
600		9070	21,000	—	—	—
750		11,500	—	—	—	—
1000	15,550	—	—	—	—	

1

Capacity Information: Natural gas regulating capacities are given for selected inlet/outlet pressures. Flows are in scfh (60°F/14.7 psia) of 0.6 SG natural gas. To determine the equivalent regulating capacities of other gases, multiply the capacity given by 0.775, and divide by the square root of the appropriate specific gravity. If capacity is desired in normal cubic meters per hour, multiply the scfh capacity given by 0.0268.

Mallard Control Model 5646C Pressure Regulator

Flow Capacities, scfh of 0.6 Specific Gravity Gas, Based on 20% Droop

Inlet Pressure (psig)	Outlet Pressure (psig)	Port Diameter (in.)				
		All Body Sizes	1" Body			
			1/8	3/16	1/4	3/8
30	20	640	1430	2500	4600	7280
50		1000	2320	4000	7800	11,300
75		1400	3000	5400	10,700	16,300
100		1800	3800	7850	14,800	18,500
150		2600	5800	11,500	20,500	—
200		3300	7350	14,300	25,200	—
400		6100	14,800	24,500	—	—
600		9070	21,000	—	—	—
750		11,500	—	—	—	—
1000		15,500	—	—	—	—
30	25	580	1000	1300	1950	2600
50		1000	1700	2300	3350	4500
75		1400	2350	3150	4650	6250
100		1000	3050	4050	5950	8000
150		2600	4350	5800	8600	—
200		3300	5700	7600	11,200	—
300		4800	8300	11,150	16,400	—
400		6400	10,900	14,700	—	—
500		8000	13,600	18,200	—	—
750		11,500	20,250	—	—	—
1000	15,500	26,850	—	—	—	
40	30	780	1620	2800	4400	5800
50		950	2100	3700	5600	7700
75		1400	3000	5000	8600	11,400
100		1800	3800	7250	10,700	16,000
150		2600	5800	10,500	16,500	23,000
200		3300	7350	12,800	21,000	29,000
300		4800	10,800	17,800	26,000	—
400		6500	13,700	23,000	28,000	—
750		11,500	23,400	30,300	—	—
1000		15,500	31,000	—	—	—
50	40	900	2000	3400	5500	7100
75		1400	3000	5000	8200	10,300
100		1800	3800	7250	10,700	16,000
150		2600	5800	10,500	16,500	25,000
200		3300	7350	12,800	22,000	33,000
300		4800	10,800	17,800	28,000	—
400		6500	13,700	23,000	32,000	—
750		11,500	25,400	34,300	—	—
1000		15,500	34,400	—	—	—
60		50	1020	2100	3900	6300
75	1350		2900	5200	8900	13,500
100	1760		3750	6900	12,500	16,800
150	2600		5800	10,500	19,000	33,400
200	3300		7350	12,300	24,000	42,500
300	4800		10,800	19,000	33,000	—
400	6500		13,700	25,000	46,000	—
750	11,500		25,400	43,400	—	—
1000	15,500		34,000	—	—	—

Inlet Pressure (psig)	Outlet Pressure (psig)	Port Diameter (in.)					
		All Body Sizes	1" Body				
			1/8	3/16	1/4	3/8	1/2
75	60	1230	2760	4880	8630	16,100	
100		1740	4010	7000	13,000	19,300	
150		2580	5850	10,500	18,900	32,800	
200		3370	7630	13,700	24,000	42,200	
300		4910	7350	20,100	32,500	69,100	
500		8090	11,200	32,900	64,000	94,300	
750		12,000	18,300	43,800	66,900	130,000	
1000		16,000	36,100	50,300	67,700	—	
1250		19,000	45,000	57,000	—	—	
1500		22,000	54,000	63,000	—	—	
1750	25,000	63,000	—	—	—		
2000	28,000	—	—	—	—		
80	75	1190	2300	3450	5000	6250	
90		1450	2900	4250	6300	7100	
100		1680	3450	4900	7600	8050	
150		2500	5400	7300	12,000	—	
200		3300	7100	9700	15,700	—	
300		4800	10,400	14,200	20,450	—	
400		6400	13,700	18,700	—	—	
500		8000	17,000	23,000	—	—	
750		11,500	25,000	—	—	—	
1000		15,500	34,000	—	—	—	
100	80	1600	3750	6650	12,200	18,600	
150		2580	5850	10,500	21,100	33,600	
200		3370	7630	13,700	28,400	44,100	
300		4910	11,200	20,100	43,300	75,400	
500		8090	18,300	32,900	71,600	110,000	
750		12,000	27,200	48,900	105,500	135,000	
1000		16,040	36,100	64,900	118,000	—	
1250		19,000	45,000	80,000	—	—	
1500		22,000	54,000	96,000	—	—	
1750		25,000	63,000	—	—	—	
2000	28,000	—	—	—	—		
110	100	1640	3500	5900	7900	9300	
125		2000	4400	7300	12,000	14,500	
150		2500	5500	9000	16,000	23,500	
200		3300	7000	12,000	21,000	34,600	
300		4800	10,500	18,000	30,100	51,000	
400		6400	13,700	25,000	44,500	70,000	
500		8040	17,200	32,000	66,000	84,000	
800		12,100	30,000	44,000	89,000	—	
1000		15,500	36,000	57,000	—	—	
135		125	1960	4200	7600	11,500	13,900
150	2340		5000	8900	15,700	20,000	
200	3300		7000	13,100	26,000	32,500	
300	4800		10,500	19,400	38,000	52,000	
400	6400		13,700	26,400	51,000	90,000	
500	8040		17,200	33,400	68,000	105,000	
800	12,100		30,000	46,500	99,000	—	
1000	15,500		36,000	63,000	—	—	
200	150		2900	7150	11,000	21,200	30,500
300			4600	11,100	19,000	31,200	45,000
400		6400	14,800	24,800	39,500	50,000	
500		8150	18,000	32,000	50,500	52,000	
750		12,000	27,000	45,000	52,500	—	
1000		15,200	35,500	58,000	—	—	

Capacity Information: Natural gas regulating capacities are given for selected inlet/outlet pressures. Flows are in scfh (60°F/14.7 psia) of 0.6 SG natural gas. To determine the equivalent regulating capacities of other gases, multiply the capacity given by 0.775, and divide by the square root of the appropriate specific gravity. If capacity is desired in normal cubic meters per hour, multiply the scfh capacity given by 0.0268.

Mallard Control Model 5646C Pressure Regulator

Flow Coefficients (C_v)

Port Diameter (in.) / Flow Co. (C _v)				
1/8	3/16	1/4	3/8	1/2
0.43	1.00	1.70	3.40	5.30

Max. Outlet Pressure

Criteria	Max. Pressure (psig)
Max. outlet pressure over pressure setting to prevent damage to internal parts.	100
Max. outlet pressure to prevent leak to atmosphere. Damage to internal parts may occur.	250
Max. outlet pressure to prevent burst of diaphragm housing. Leak to atmosphere and damage to internal parts may occur.	400

Overpressure Protection: The model 5646C regulator's outlet pressure rating is lower than its inlet pressure rating. Consequently, overpressure protection is required if the actual inlet pressure of a given application can exceed the regulator's outlet pressure rating. To avoid overpressure, the user must provide an appropriate pressure relieving or pressure limiting device to ensure that none of the limits shown are exceeded.

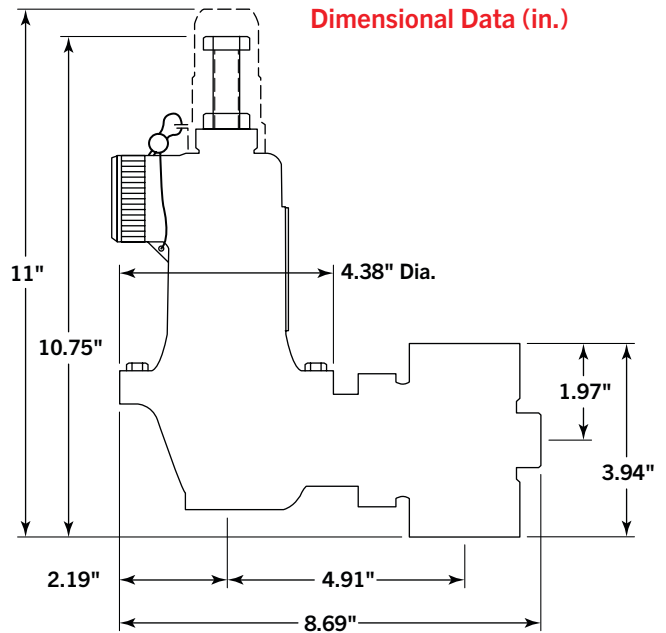

Maximm Inlet / Differential Pressures

Spring Range	Orifice (in.)	Max. Inlet Pressure (psig)	Max. Differential Pressure (psig)
5 to 20 psig	1/8	125	125
	3/16	125	125
	1/4	125	125
	3/8	125	125
	1/2	100	100
15 to 40 psig	1/8	1000	1000
	3/16	600	600
	1/4	400	400
	3/8	200	200
	1/2	100	100
35 to 80 psig	1/8	1000	1000
	3/16	1000	1000
	1/4	800	800
	3/8	500	500
	1/2	250	250
10 to 95 psig	1/8	1000	1000
	3/16	1000	1000
	1/4	1000	1000
	3/8	600	600
	1/2	350	350
70 to 150 psig	1/8	1000	1000
	3/16	1000	1000
	1/4	1000	1000
	3/8	800	800
	1/2	500	500

Part Number Codes

