

# McMATH

EDMONTON

CALGARY

CONTROLS & AUTOMATION INC

#100 - 7503 Girard Road, Edmonton, AB T6B 2H2

Tel.780.463.6366 Fax.1.888.528.2785 Toll Free.1.800.817.6493

# MALLARD CONTROL

A BRAND OF  Taylor Valve Technology

TRUSTED  
**SINCE 1958**  
WORLDWIDE

## 5600

Precise.

---

Quality.

---

Reliable.

---



SINCE **1958**



# Mallard Control Model 5600 Pressure Regulator Valve

## Features

- > Easy maintenance
- > Variety of flow capacities
- > Rugged construction
- > Excellent control at low pressure settings
- > NACE compliance
- > Suitable for air and gas

## Specifications

Model 5600 pressure regulator  
 End connections  
 1" & 2" NPT female  
 Operating temperature  
 -20° to 150°F (-29° to 65°C)

The model 5600 pressure regulator pressure relief valve is spring-loaded, self-operated and available in 1" and 2" sizes. It provides economical control of air, natural gas and a variety of other gases and is built to withstand the most difficult processes and

environments. It is designed for inlet pressures up to 1500 psig and outlet pressures from 27 to 500 psig. Model 5600 is well suited for high pressure, high capacity applications.



*Model 5600  
Pressure Regulator*

## Table of Contents

Model 5600 Pressure Regulator Features, Materials, Specs & Component Parts . . . . . 2-3

Model 5600 Pressure Regulator Flow Capacities . . . . . 4-5

Model 5600 Pressure Regulator Dimensional Data, Part Number Codes & Pressure Data . . . . . 6-7

## Mallard Control Model 5600 Pressure Regulator Valve

### Component Parts

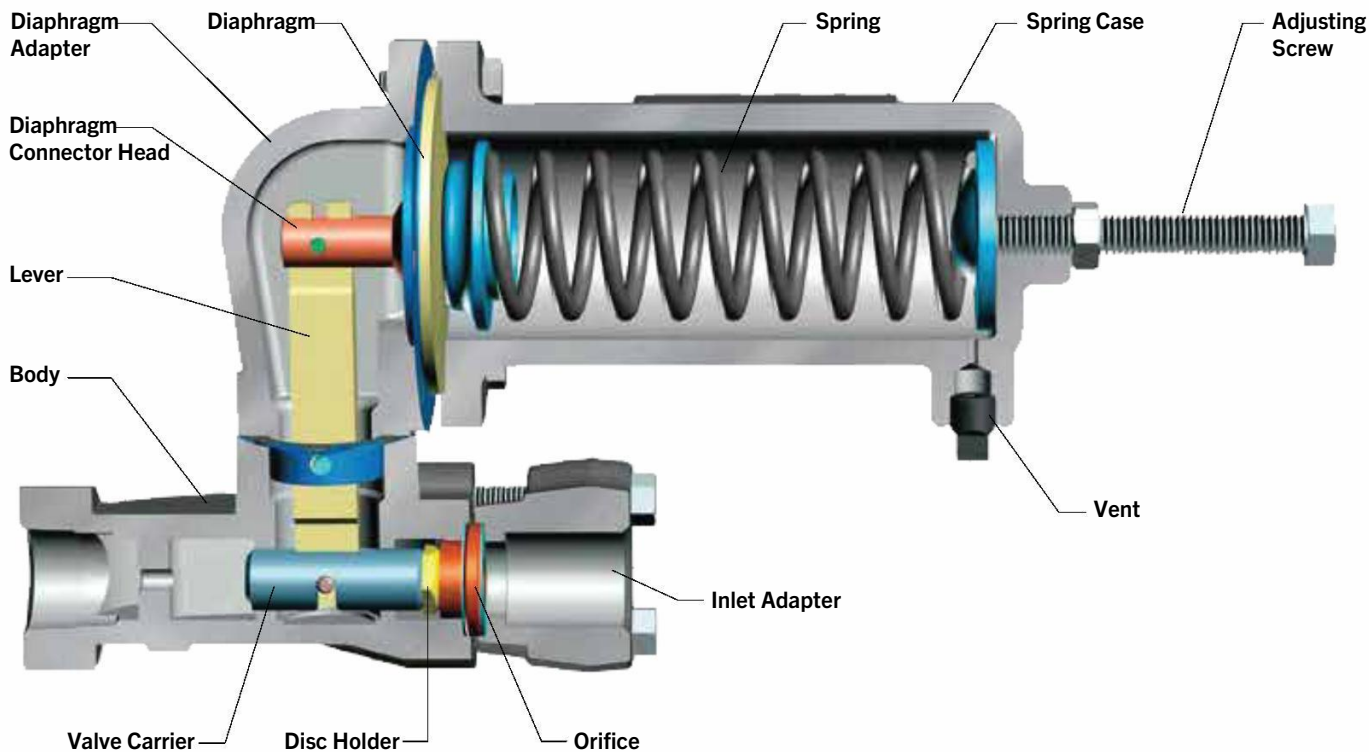

### Materials of Construction

Description	Material
Body	Carbon Steel
Inlet Adapter	Steel
Diaphragm Adapter	Ductile Iron Steel (Optional)
Spring Case	Ductile Iron Steel (Optional)
Orifice	Brass Stainless Steel (Opt.)
Valve Disc	Nylon or TFE Viton® (Optional)

Description	Material
Disc Holder	Brass Stainless Steel (Opt.)
Valve Carrier	Brass Stainless Steel (Opt.)
Diaphragm	Buna-N (Embedded Nylon Fabric) Viton® (Optional)
Lever	Steel
Diaphragm Connector Head	Brass Stainless Steel (Opt.)

### Flow Coefficients (C<sub>v</sub>)

Port Diameter (in.)	Flow Coefficient (C <sub>v</sub> )
1/8	0.49
3/16	1.11
1/4	2.03
3/8	4.61
1/2	8.18

# Mallard Control Model 5600 Pressure Regulator Flow Capacities

Pressure, scfh of 0.6 Specific Gravity Gas, Based on 20% Droop

Inlet Pressure (psig)	Outlet Pressure (psig)	Port Diameter (in.)										
		1" NPT					2" NPT					
		1/8	3/16	1/4	3/8	1/2	1/8	3/16	1/4	3/8	1/2	
60	50	900	2000	3100	5200	8100	1000	2100	3200	5300	12,000	
75		1300	2800	3800	7200	10,000	1400	2900	3900	7300	16,000	
100		1700	3500	5700	10,500	13,000	1800	3600	5800	10,000	21,000	
150		2600	5700	8700	13,000	17,000	2700	5800	9000	15,000	36,000	
200		3500	7800	11,000	16,000	19,000	3600	7900	12,000	21,000	55,000	
300		5300	10,500	14,000	20,000	23,000	5500	11,000	19,000	48,000	83,000	
400		6900	13,000	17,000	23,000	—	7000	15,000	27,000	63,000	—	
550		9600	16,000	20,000	26,000	—	9700	21,000	38,000	88,000	—	
600		9800	17,000	21,000	—	—	10,000	23,000	42,000	—	—	
1050		17,000	23,000	27,000	—	—	19,000	42,000	74,000	—	—	
1500		19,000	25,000	—	—	—	27,000	60,000	—	—	—	
60		50	800	1500	2400	4300	6400	900	1600	2500	4400	7300
75			1200	2100	3100	5500	8000	1300	2200	3200	6100	9300
100			1500	3100	4200	7500	10,000	1600	3400	4300	7600	12,000
150			2400	4500	6700	11,000	14,000	2500	4600	7100	12,000	19,000
200	3400		6600	9400	14,000	17,000	3500	6700	9600	16,000	27,000	
300	5200		8900	11,000	16,000	20,000	5300	10,000	14,000	27,000	51,000	
400	6800		11,000	15,000	20,000	—	6900	13,000	21,000	46,000	—	
550	9500		13,000	17,000	23,000	—	9600	18,000	29,000	87,000	—	
600	9800		14,000	19,000	—	—	10,000	20,000	35,000	—	—	
1050	14,000		19,000	22,000	—	—	18,000	41,000	73,000	—	—	
1500	18,000		24,000	—	—	—	26,000	59,000	—	—	—	
100	75		1700	3200	5000	8000	13,000	1800	3300	5200	9000	14,000
125			2200	4300	6700	10,000	15,000	2300	4400	6900	11,000	18,000
200			3500	7300	10,000	16,000	22,000	3600	7400	11,000	19,000	30,000
250			4400	9400	13,000	19,000	24,000	4500	9500	14,000	26,000	44,000
325		5700	11,000	16,000	23,000	27,000	5800	12,000	18,000	36,000	67,000	
400		7100	14,000	19,000	27,000	—	7200	15,000	24,000	47,000	—	
575		9700	18,000	23,000	30,000	—	9800	22,000	37,000	92,000	—	
600		9900	19,000	25,000	—	—	10,000	23,000	39,000	—	—	
1075		18,000	27,000	32,000	—	—	19,000	42,000	75,000	—	—	
1500		23,000	32,000	—	—	—	24,000	60,000	—	—	—	
125		100	2000	3600	5500	9200	13,000	2100	3700	5600	9800	15,000
150			2500	4600	6800	11,000	16,000	2600	4900	7400	12,000	18,000
200			3600	6600	9400	13,000	22,000	3700	6900	10,000	17,000	27,000
250			4400	8500	11,000	18,000	26,000	4500	8700	13,000	22,000	34,000
300			5300	9800	14,000	21,000	30,000	5400	10,000	16,000	27,000	44,000
350	6100		10,000	16,000	25,000	32,000	6300	12,000	19,000	33,000	57,000	
400	7000		13,000	18,000	27,000	—	7200	14,000	21,000	39,000	—	
600	9500		18,000	23,000	35,000	—	10,000	21,000	34,000	69,000	—	
1100	19,500		28,000	35,000	—	—	19,000	43,000	74,000	—	—	
1500	25,000		35,000	—	—	—	27,000	59,000	—	—	—	
150	125		2400	4600	6700	11,000	17,000	2500	5000	8100	12,000	20,000
200			3500	6800	10,000	15,000	23,000	3600	7400	11,000	19,000	30,000
250			4300	8900	12,000	19,000	29,000	4400	9400	14,000	24,000	39,000
300			5200	10,000	15,000	25,000	34,000	5300	11,000	17,000	31,000	48,000
375			6600	13,000	18,500	28,000	39,000	6600	13,600	21,400	38,300	59,400
400		7300	14,500	19,000	29,000	—	7300	15,000	24,000	43,000	65,000	
500		7900	15,000	25,000	36,000	—	8800	19,000	30,000	59,000	—	
625		10,000	22,000	29,000	41,000	—	11,000	24,000	40,000	79,000	—	
1125		18,000	33,000	42,000	—	—	19,000	44,000	79,000	—	—	
1500		26,000	43,000	—	—	—	27,000	60,000	—	—	—	

## Mallard Control Model 5600 Pressure Regulator Flow Capacities

Pressure, scfh of 0.6 Specific Gravity Gas, Based on 20% Droop (Continued)

Inlet Pressure (psig)	Outlet Pressure (psig)	Port Diameter (in.)									
		1" NPT					2" NPT				
		1/8	3/16	1/4	3/8	1/2	1/8	3/16	1/4	3/8	1/2
200		3400	6800	10,000	16,000	26,000	3500	7300	11,000	18,000	30,000
250	150	4400	8800	13,000	20,000	32,000	4500	9500	15,000	26,000	38,000
300		5300	10,000	15,000	24,000	35,000	5400	11,000	19,000	32,000	52,000
400	90 to 150	7100	14,000	22,000	34,000	42,000	7200	15,000	26,000	46,000	77,000
450	or	7700	17,000	24,000	36,000	—	8100	18,000	29,000	54,000	—
650	150 to 200	9000	24,000	33,000	49,000	—	10,000	25,000	44,000	88,000	—
800	psig	13,000	29,000	38,000	—	—	14,000	30,000	54,000	—	—
1150	Spring	20,000	38,000	49,000	—	—	21,000	46,000	78,000	—	—
1500		26,000	47,000	—	—	—	27,000	60,000	—	—	—
250		4200	8300	12,000	20,000	30,000	4300	9100	13,000	23,000	42,000
300	200	5200	10,000	16,000	25,000	35,000	5300	11,000	18,000	33,000	52,000
450		7800	16,000	26,000	43,000	50,000	7900	17,000	29,000	52,000	84,000
600	150 to 200	9500	22,000	34,000	55,000	—	10,000	23,000	40,000	75,000	—
700	or	11,000	25,000	40,000	61,000	—	12,000	27,000	47,000	90,000	—
800	200 to 275	13,000	30,000	43,000	—	—	14,000	31,000	54,000	—	—
1000	psig	16,000	37,000	50,000	—	—	17,000	39,000	69,000	—	—
1200	Spring	20,000	41,000	59,000	—	—	21,000	48,000	83,000	—	—
1500		26,000	53,000	—	—	—	27,000	60,000	—	—	—
300		4900	9000	15,000	28,000	42,000	5000	10,000	17,000	30,000	52,000
400	250	7000	14,000	23,000	40,000	56,000	7100	15,000	25,000	47,000	76,000
500		8500	18,000	29,000	51,000	65,000	8600	19,000	34,000	62,000	103,000
600	200 to 275	9500	22,000	34,000	59,000	—	10,000	23,000	41,000	78,000	—
750	psig	12,500	28,000	44,000	69,000	—	13,000	29,000	51,000	106,000	—
1000	Spring	16,000	39,000	58,000	—	—	17,000	40,000	68,000	—	—
1250		21,000	49,000	69,000	—	—	22,000	50,000	87,000	—	—
1500		26,000	59,000	—	—	—	27,000	60,000	—	—	—
300	275	4700	9000	15,000	28,000	39,000	4800	10,000	17,000	29,000	43,000
400		6900	14,000	25,000	40,000	54,000	7000	15,000	26,000	47,000	73,000
525	200 to 275	8600	18,000	35,000	68,000	94,000	9200	20,000	36,000	69,000	112,000
775	or	11,000	28,000	51,000	95,000	—	12,000	30,000	52,000	112,000	—
1000	275 to 500	16,000	39,000	67,000	—	—	17,000	40,000	68,000	—	—
1275	psig	21,000	50,000	87,000	—	—	22,000	51,000	89,000	—	—
1500	Spring	26,000	60,000	—	—	—	26,000	61,000	—	—	—
400		6600	11,000	16,000	31,000	42,000	7000	13,000	21,000	35,000	54,000
550	300	9700	18,000	23,000	44,000	63,000	9800	20,000	30,000	52,000	78,000
600		9900	19,000	26,000	48,000	—	10,000	21,000	34,000	59,000	—
700	275 to 500	11,000	23,000	30,000	54,000	—	12,000	26,000	40,000	72,000	—
800	psig	13,000	26,000	35,000	61,000	—	14,000	29,000	47,000	81,000	—
900	Spring	15,000	29,000	39,000	—	—	16,000	34,000	53,000	—	—
1300		22,000	43,000	58,000	—	—	23,000	50,000	80,000	—	—
1500		26,000	49,000	—	—	—	27,000	58,000	—	—	—
500		8300	16,000	24,000	44,000	62,000	8800	17,000	28,000	49,000	77,000
650	400	10,000	24,000	33,000	61,000	86,000	11,000	25,000	40,000	75,000	112,000
800		13,000	30,000	41,000	76,000	—	14,000	31,000	51,000	95,000	—
900	275 to 500	15,000	34,000	49,000	85,000	—	16,000	36,000	58,000	110,000	—
1000	psig	17,000	38,000	54,000	—	—	18,000	40,000	66,000	—	—
1200	Spring	20,000	46,000	63,000	—	—	21,000	48,000	80,000	—	—
1400		24,000	55,000	76,000	—	—	25,000	57,000	96,000	—	—
1500		26,000	60,000	—	—	—	27,000	61,000	—	—	—
550	500	8700	16,000	26,000	50,000	77,000	9000	18,000	30,000	53,000	89,000
750		12,000	28,000	40,000	78,000	100,000	13,000	29,000	48,000	90,000	141,000
900	275 to 500	15,000	34,000	52,000	92,000	—	16,000	35,000	60,000	113,000	—
1000	psig	17,000	39,000	60,000	100,000	—	18,000	40,000	67,000	130,000	—
1500	Spring	26,000	59,000	72,000	—	—	27,000	60,000	82,000	—	—

NOTE: Taylor Valve reserves the right to change product designs and specifications without notice.

## Mallard Control Model 5600 Pressure Regulator Valve

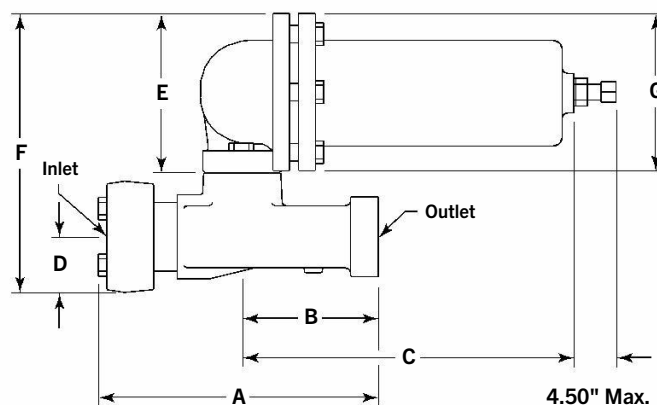

Model 5600

### Dimensional Data (in., mm), Model 5600

Model	Dimension (in., mm)													
	A		B		C		D		E		F		G	
	in.	mm	in.	mm	in.	mm	in.	mm	in.	mm	in.	mm	in.	mm
5600 - 1"	7.38	187.45	3.69	93.73	9.12	231.65	1.19	30.23	4.82	122.43	7.94	201.68	4.75	120.65
5600 - 2"	7.88	200.15	3.94	100.08	9.12	231.65	2.00	50.80	4.82	122.43	8.63	219.20	4.75	120.65

CAUTION: Model 5600 regulators have an outlet pressure rating that is lower than the inlet pressure rating. Consequently, overpressure protection is required if the actual inlet pressure can exceed the regulator's outlet pressure rating. To avoid overpressure, provide an appropriate overpressure protection device to ensure that none of the limits listed will be exceeded. Internal parts of the regulator may be damaged if the outlet pressure exceeds the pressure setting beyond the amounts shown.

1. This applies to outlet pressure settings below 350 psig only. For pressure setting above 350 psig, outlet pressure is limited to 550 psig, the maximum emergency outlet pressure.

Outlet Pressure Range (psig)	High Pressure (psig)	
	Max. Outlet Pressure Over Pressure Setting	Max. Emergency Outlet Pressure
27 to 50	200	550
46 to 95		
90 to 150		
150 to 200		
200 to 275		
275 to 500	200 <sub>1</sub>	

### Maximum Inlet & Differential Pressures

Port Diameter (in.)	Max. Allowable Inlet Pressure (psig)	Max. Allowable Pressure Drop (psid)	
		TFE/Nylon Disc	Viton® Disc
3/16, 1/8	1500	1500	200
1/4	1500	1000	
3/8	1000	500	
1/2	750	250	

The sum of the outlet pressure setting and the maximum allowable pressure drop determines the maximum allowable inlet pressure for a given installation. For example, with a 1/2" port diameter (maximum pressure drop of 250 psi) and a 400 psig outlet pressure setting, the maximum inlet pressure is 650 psig (250 psi plus 400 psig).

## Mallard Control Model 5600 Pressure Regulator Valve

### Part Number Codes

#### Model

**None** • Regulator

#### Body Size & End Connection

- 1 • 1" FNPT
- 2 • 2" FNPT

#### Style

**H** • Standard Pressure (Spring Code E-K)

#### Body Material

**W** • Carbon Steel

#### Outlet Pressure Range

##### Outlet Pressure Range

- E** • 27 to 50 psig
- F** • 46 to 95 psig
- G** • 90 to 150 psig
- H** • 150 to 200 psig
- J** • 200 to 275 psig
- K** • 275 to 500 psig

#### Trim Material

##### Model 5600 Only

- W** • Stainless Steel / TFE (For Pressure Drops up to 1500 psi)
- X** • Stainless Steel / Nylon (For Pressure Drops 200 to 1500 psi)
- Y** • Stainless Steel / Viton® (For Pressure Drops Below 200 psi)

Note: Reference "Maximum Inlet & Differential Pressures" chart on page 8.

#### Port Diameter

- 1 • 1/8"
- 2 • 1/4"
- 3 • 3/8"
- 4 • 1/2"
- 5 • 3/16" (Model 5600 Only)

#### Options

**S** • None

5600 - 1 HWG-W4 S  
Example



Taylor Valve Technology  
8300 S.W. 8th Street  
Oklahoma City, Oklahoma 73128

TEL 405.787.0145

FAX 800.805.3401

WEB [www.taylorvalve.com](http://www.taylorvalve.com)

EMAIL [info@taylorvalve.com](mailto:info@taylorvalve.com)



Precise.

Quality.

Reliable.