

Model 3100E & 3100P/P1 Liquid Level Switches

Specifications

Model 3100E

Process connection: 2" MNPT
Maximum operating pressure
Stainless steel float - 500 psig
Polystyrene float - 2000 psig
Minimum operating specific gravity
316 stainless steel float: 0.68
Polystyrene float: 0.50
Leadwires: 18 AWG x 36" long

Model 3100P/P1

Process connection: 2" MNPT
Maximum operating pressure
Stainless steel float - 500 psig
Polystyrene float - 2000 psig
Supply pressure connection
1/8" FNPT
Exhaust connection: 1/4" FNPT
Supply pressure: 30 to 60 psig
Minimum operating specific gravity
316 stainless steel float: 0.68
Polystyrene float: 0.50

The model 3100E is an electric, float-operated switch which can be used as a high or low level alarm or for liquid level control.

*Model 3100E
Electric Level
Switch*

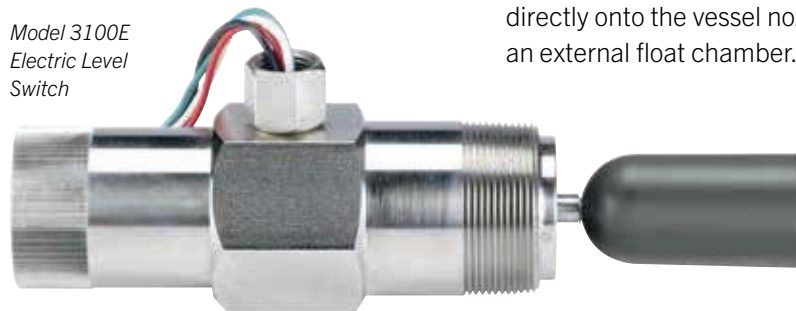

The 3100E is rated for high pressure applications, and the polystyrene float will effectively and consistently operate the switch at specific gravities as low as 0.50. The switch can be mounted directly onto the vessel nozzle or into an external float chamber.

The model 3100P and 3100P1 are pneumatic, float-operated switches for liquid level control. The 3100P is a 2-way normally-open or normally-closed switch and the 3100P1 is a 3-way block-and-bleed switch. The 3100P and 3100P1 are rated for high pressure applications, and the polystyrene float will effectively and

*Model 3100P/P1
Pneumatic Level Switch*

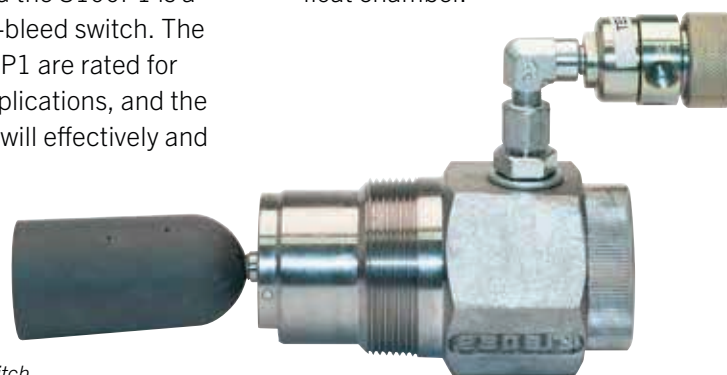

consistently operate the switch at specific gravities as low as 0.50. Both models can be mounted directly onto the vessel nozzle or into an external float chamber.

NOTE: Taylor Valve reserves the right to change product designs and specifications without notice.

Model 3100E & 3100P/P1 Liquid Level Switches

Dimensional Data (in.)

Model 3100E

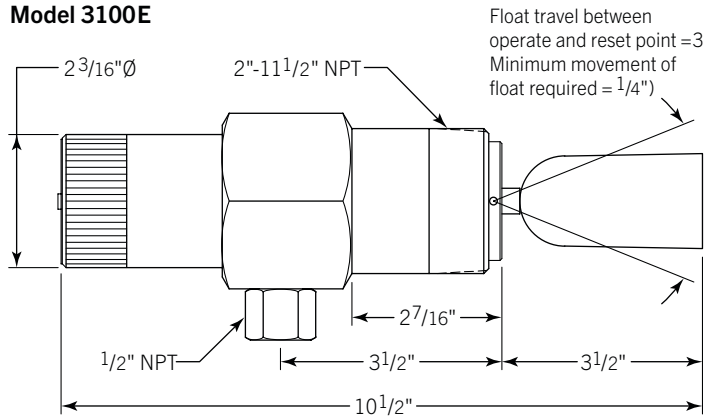

External Float Chamber - P/N 31124-1 (Standard)
P/N 31124N-1 (NACE)

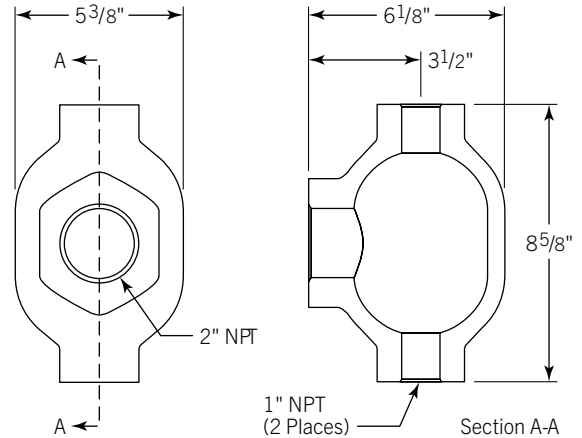

Model 3100P/P1

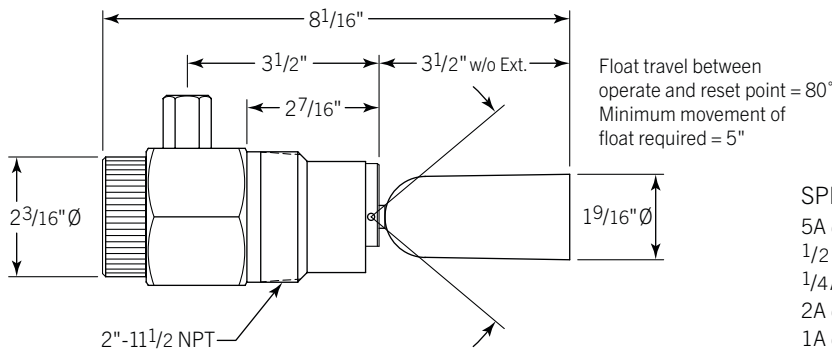

SPDT Switch Rating
5A @ 125-250-480 VAC
1/2 A @ 125 VDC
1/4 A @ 250 VDC
2A @ 6-30 VDC Resistive
1A @ 6-30 VDC Inductive

DPDT Switch Rating
10A @ 125-250 VAC
1/2 A @ 125 VDC
1/4 A @ 250 VDC
10A @ 6-24 VDC
Inductive/Resistive

Part Number Codes, Model 3100E

Part Number	Model Number	Body	Float (Viton® Seals)	Switch
91200	3100E	CS	Polystyrene	SPDT
91201	3100E2	CS	Polystyrene	DPDT
91210	3100E2	CS	SS	DPDT
91219	3100E	CS	SS	SPDT
91224	3100E2-SS	SS	SS	DPDT
91225	3100E-SS	SS	SS	SPDT
91227	3100E-SS	SS	Polystyrene	SPDT
91232	3100E2-SS	SS	Polystyrene	DPDT

Part Number Codes, Model 3100 P/P1

Part Number	Model Number	Body	Float (Viton® Seals)	Pilot
91000	3100P	CS	Polystyrene	No
91001	3100P1	CS	SS, 1" Ext.	Yes
91002	3100P	CS	SS	No
91004	3100P1	CS	SS	Yes
91006	3100P1	CS	Polystyrene	Yes
91008	3100P-SS	SS	Polystyrene	No
91025	3100P1-SS	SS	Polystyrene	Yes
91026	3100P1-SS	SS	SS	Yes
91027	3100P1-SS	SS	SS	No
91206	3100P1	CS	Poly., 1" Ext.	Yes
91207	3100P	CS	Poly., 1" Ext.	No

Materials of Construction

Description	Material
Body	WCC
	316 Stainless Steel (Optional)
Float	Polystyrene
	316 Stainless Steel (Optional)
Seals	Viton®

Temperature Limits

Model 3100E & 3100P/P1	
Polystyrene Float	Stainless Steel Float
-20 to 300°F (-29 to 200°C)	-20 to 400°F (-29 to 204°C)